

INSTRUCTIONS TO MODIFY 2-A and 2-B RECEIVERS FOR A BAND
COVERAGE OF FREQUENCIES 1.8 to 2.0 KC
(Serial Numbers Higher Than 1000 Only)

This modification will be performed at the factory for a charge of \$12.50. This includes all parts, labor, and crystal, but does not include shipping charges via Rail Express to or from Miamisburg.

Field service and modification instructions are intended for execution by competent electronics technicians. Damage resulting from incompetence, carelessness, or negligence will not be covered by our warranty.

1. Remove chassis from cabinet. Lay receiver on its panel, remove the six screws in bottom cabinet, and pull case up, off the rear of chassis.
2. Place chassis upside down on table with panel toward you. Notice the "T" shaped partition (near the front, right corner) with a band switch wafer on each side and trimmer condenser at right.
3. Install another trimmer identical to the one in the set (Arco part No. 4625-80 mmf), in the holes provided. Use same method of attachment and be sure that the gnd. and hot lugs are positioned same as the ones on the original trimmer. BE CAREFUL NOT TO MOVE THE SMALL WHITE INCREMENT COILS SOLDERED TO SWITCH WAFER AS ALIGNMENT ON 15 and 20 METERS WILL BE SPOILED.
4. On each of the two switch wafers, remove a jumper wire which runs between 80M contact and A contact (rotate the band switch knob and watch the blade of the rotor to pick out the two contacts on each wafer. The wafers are identical.)

While working around the switch wafers with a soldering iron, BE CAREFUL, do not overheat the switch contacts, they will become loose or lose their spring temper. Do not try to clean the wafer with any solvent. Do not let solder run down the contacts.

5. Run a short wire from the A contact of the front wafer to the "hot" term. of the trimmer.
6. Connect CA (1330 pf for 160) (mmf silver mica, dipped type preferred) across the terminals of the trimmer.
7. Connect the gnd. terminal of the trimmer to the grounded wire which runs down from the original trimmer to the wiper lug of the preselector variable condenser.
8. Connect CB (1390 pf for 160) (mmf silver mica, dipped typed preferred) from the A contact of the rear wafer to the coil terminal which is the junction of a 1500 ohm resistor and a 180 mmf dipped mica capacitor.

9. Insert a 5.5mc for 160 mc crystal in the A socket and turn band switch to the A position.
10. Tune in a strong steady signal (such as 100 KC Crystal calibrator signal) at 1900 KC and peak the new trimmer while rocking the preselector slightly to each side of peak as read on the S-Meter.
11. Turn chassis face down on panel and replace cabinet and six cabinet screws.
12. The A Band will now tune 1.8-2.0mc.
13. The original A Band range of 4100 - 4500 KC of course now cannot be received.

Coverage 1.8 - 2.0 mc

Crystal Freq. 5.5 mc Band/Crystal socket A

LOG SCALE							
	500	400	300	200	100	0	-100
Preselector	Freq. Mc.						
0 - 10	2.0	1.9	1.8				

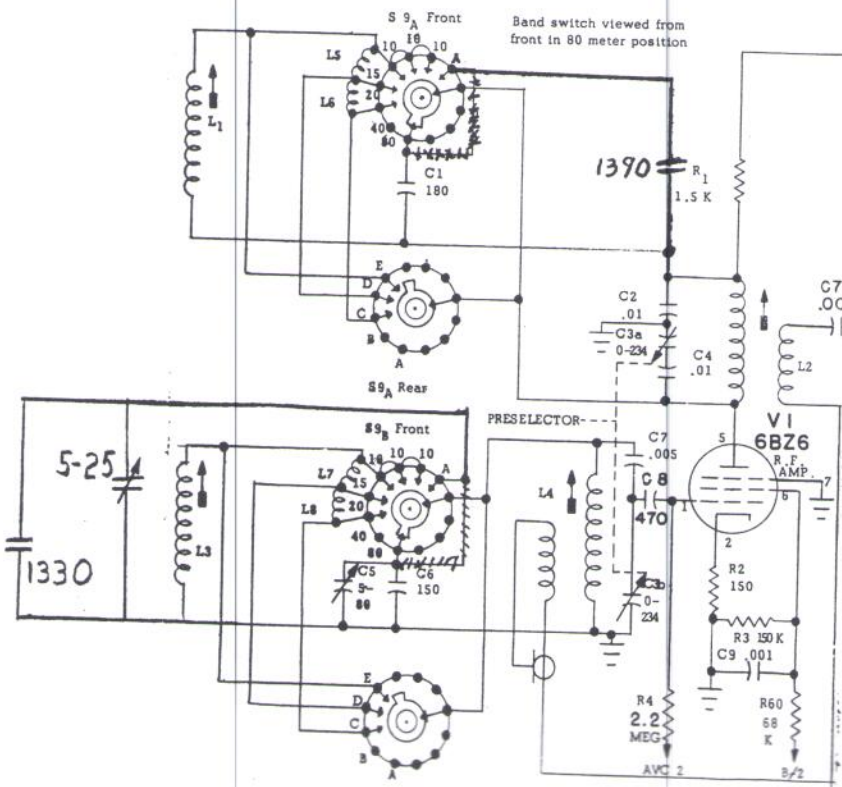

PARTS REQUIRED:

- 1330 mmf silver mica capacitor (dipped type preferred)
- 1390 mmf silver mica capacitor (dipped type preferred)
- 5-25 mmf mica trimmer capacitor
- 5.5 mc Fundamental crystal